

Landscape Architect Registration Examination

Preparatory Courses

LARE Overview
and Sections A, B & D

January 20-22, 2011

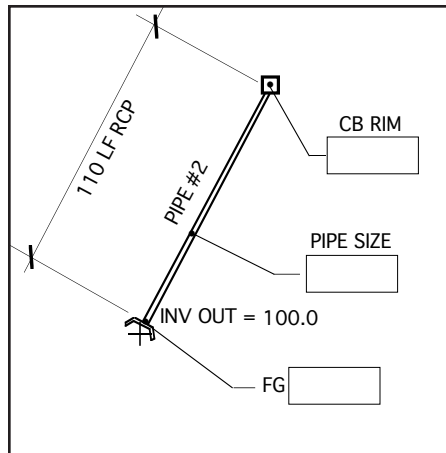
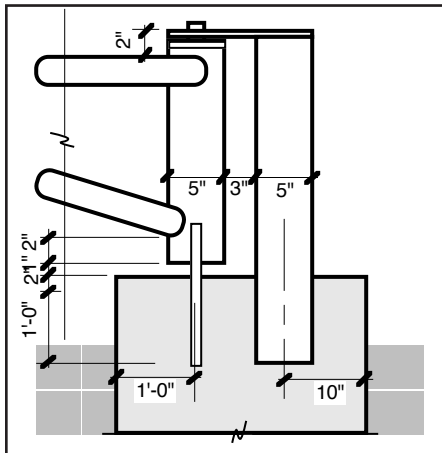

Freeman & Jewell Landscape Architecture

Freeman & Jewell

Landscape Architecture

1422 Peralta Avenue
Berkeley, CA 94702

Freeman & Jewell Landscape Architecture is once again offering our popular series of preparatory courses for candidates taking the Landscape Architect Registration Examination. These courses have attracted students from all over California as well as 35 other states, the District of Columbia, five Canadian Provinces, Puerto Rico and Germany.

The courses for the multiple choice (A,B&D) sections are offered in Northern California approximately six weeks prior to the exam.

In the spring and fall, Freeman & Jewell offers weekend courses covering the two performance sections of the examination as well as an overview of the exam as it applies to these sections:

E: Grading, Drainage and Stormwater Management
Scheduled for April 13-15, 2012.

C: Site Design and Planning
Scheduled for April 27-29, 2012

Our Performance Section classes are generally given during the months of April and October. The Multiple Choice Section classes are generally given in January and July.

An Overview of the LARE and Intensive Review of the Objective Sections

Sections A, B and D of the LARE Landscape Architects Registration Examination

Through lecture, group discussion, and practice tests, this intensive three day course focuses on preparing students to take the LARE, concentrating on the multiple choice sections of the exam as well as providing a detailed overview of the exam structure. Specific sections of the LARE to be covered include:

Section A: Project and Construction Administration
Section B: Inventory, Analysis and Program Development
Section D: Design and Construction Documentation

The course includes an in depth overview of the exam and the fundamentals of the impact of a wide variety of typical issues and challenges which affect the design and construction processes, as well as regulatory and professional practice impacts on Landscape Architecture. Each student will receive a course binder containing over 500 pages of information pertinent to the exam, focusing on sections A, B& D.

The program includes

- Overview of the LARE; Structure of the exam
- How the exam is scored; Exam preparation strategies and tips
- Project and Construction Administration
- Project Assessment and Review
- Problem Definition
- Inventory and Analysis
- Project Programming
- Development and Evaluation of Alternatives
- Design Principles
- Resource Conservation and Analysis
- Graphic Communication
- Construction Documentation
- Materials and Methods of Construction

Students will be given a grounding in the format, goals and requirements of the LARE. Lectures on a variety of topics tested by the exam and encountered in professional practice will be given over all three days. An extensive list of typical questions specific to each objective section of the exam will be given out and used as mock timed exams of Sections A, B and D. The questions and answers will be then be reviewed as a group exercise led by the instructors.

Overview and Sections A, B & D Who Should Attend

This course would benefit candidates for the LARE who are taking the exam for the first time or are having difficulty with any of the objective sections. Additionally, individuals who would like to further their knowledge of technical and administrative aspects of the topics covered by these sections of the exam could benefit.

Instructors

Ray Freeman is a principal of Freeman & Jewell Landscape Architecture in Berkeley, CA and has over 33 years of experience as a landscape architect. He is also a Certified Professional Erosion and Sedimentation Control Specialist. He has taught as a lecturer at UC Berkeley, Cal Poly San Luis Obispo, UC Davis Extension, Merritt College and Harvard University.

Sarah Gronquist is a landscape architect and project manager at Chuck McCulloch Landscape Architects. She holds an MLA from the University of Massachusetts, Amherst.

Date, Time and Location

Friday-Sunday, January 20-22, 2012. Friday, Saturday and Sunday
8:30 am-6:00 pm. Location: YMCA Point Bonita, Golden Gate National Recreation Area, Marin County. A map and directions will be furnished upon enrollment.

Each participant will need to bring the following supplies

- Architect and engineers scales
- Pencils or leadholders and erasers
- Highlighter
- Calculator with square root capability
- Notepad

NOTE: Our classes are all current with the newest (2006) exam format, and our material is updated every six months.

For More Information

For specific information or questions:

E-mail: (this is the preferred method for contact) Rayfreeman3@comcast.net

You may also call (510) 528-0375. You may also fax questions to this number.
In all cases, please leave an e-mail address for replies.

Registration Deadlines

Enroll early! Class size is limited. Due to the requirements of our contract with the YMCA, the following deadline has been set for registration: January 7, 2012.

Registration applications which are postmarked after the deadline for registration will be charged an additional \$25.00.

Cancellation & Refund Policy

Classes may be cancelled or rescheduled due to circumstances beyond our control. In the event a class is cancelled, a full refund will be made for that class.

If your plans change and you will not be able to attend a class for which you have registered, a refund (less a \$75 processing fee) will be given if the cancellation notice is received by the registration deadline given above. Cancellations after the deadline will be charged \$100.00.

About the location

The YMCA Point Bonita Conference Center is located between the Point Bonita Lighthouse and Rodeo Beach and is within the Golden Gate National Recreation Area. Their website is at <http://www.ymcasf.org/ptbonita/> The YMCA facility is within easy walking distance of the Point Bonita Lighthouse, Rodeo Beach and Rodeo Lagoon. Waterfowl and wildlife abound on and adjacent to the campus. The Marin Headlands area offers wonderful views of the coast, San Francisco and the Golden Gate Bridge, hiking, bicycling, camping, and picnicking opportunities.

The principal instructor stays at the YMCA throughout the weekend, acting as host, leading night time hikes, answering LARE questions, and generally trying to make everyone's stay enjoyable.

Comments by former students

*"I recently found out that I passed all three LARE multiple choice tests. I am absolutely positive that had I not taken your prep course, the results would have been different. Thank you for preparing us so well. Time and money well spent!!
Jeanna Menze, Sonoma, CA Jan 09*

Section D was difficult. I finally took your course after failing the second time, then passed the 3rd time. I believe it was your helpful course that finally gave me everything I needed to pass. Thanks! Bethany Noblin, Greenville, SC Jan 2011

"Thank you, thank you, thank you! I have passed all of the parts of the test! If it wasn't for your review courses I would not have had a clue. The description of the test and the review materials you provided were concise and accurate to the problems on the current exam." Stewart McCord, Sacramento, CA Spring 02

"The (A,B,D) course was excellent and worth every penny." Scott Blair Spring 03

"I thought the questions on the exam correlated to your class syllabus nicely. Thank you for a great preparation class." Wes Simmonds, Seattle WA Aug 06

"I just wanted you to know that passing any of the exams on the first try would have been imposable if it wasn't for taking your review classes. I thought the classes were very well dont and I am going to recommend them to anybody who is planning on signing up to take the LARE exam." Andrew Headington, SF Jul 07

"I did take ABD in September and passed all three! Thank you for a fantastic course. I will definitely recommend your courses to anyone preparing for the LARE. Your courses were excellent, and truly made the difference for me." Dorothy Sacerdote, Palo Alto, CA Jan 07

"I PASSED ALL THREE, WOW, this is awesome. Thank you so much for your class and help. Everything you gave us prepared us so well for the test. I will see you in May for the next class." Chris Chisam, Sacramento, CA Jan 09

"Great comprehensive review course. I value the time taken to review so much material and being able to walk away with a well organized book of information."

"Instructors were well prepared, knowledgeable and organized. Materials well prepared, explanations concise and great inclusion of current information. Excellent!"

Complete the form and mail it to

Freeman & Jewell Landscape Architecture
1422 Peralta Avenue
Berkeley, CA 94702

Note: The facility has imposed a significant use fee increase this year, we are therefore obliged to increase our rates accordingly.

1. Fees

The fee for this class is \$475 if your registration is postmarked **January 7, 2012** or earlier. After **January 7**, the registration fee is \$500.

Lunch all three days is included in the course fees.

Complimentary coffee and tea, soft drinks, bottled water and light snacks are provided as part of the course.

2. Room and Board Options

You may sign up to spend the night at the YMCA as part of the course package. You may also sign up for Breakfast and/or Dinner as well. Vegetarian or Vegan options on all meals may be requested. Meals are cafeteria style, all you can eat. **The food is really very good.** The closest commercial eating establishments are in Sausalito, 15 minutes away.

Bunkhouse style accommodations: You will need to bring your own sleeping bag or bedclothes, pillow, washcloth, towels, and toiletries. Flashlights are highly recommended for night time hiking.

The following options are available:

Option 1: 3 Nights stay with 5 extra meals (Room: Thu, Fri, Sat ...Breakfast Friday thru lunch Sunday) [\$120]

Option 2: 2 Night stay with 4 extra meals (Room: Fri, Sat ...Lunch Friday thru lunch Sunday) [\$85]

Option 3: Room Fri and Sat only, no extra meals. [\$50]

Linen: Pillows, sheets, blankets, washcloths and towels provided by the YMCA for your stay. [\$30]

Extra nights are \$30/person/night. Extra meals are \$11 each.

For example, you can usually stay at the Y on the Sunday night after class if requested in advance. Dinner Thursday night may be arranged, if available. Check with us in advance.

Due to planning requirements of the YMCA, you must sign up for the room and board options at the same time you register for classes.

Please return the Enrollment/Payment form on the next page with your check made out to Freeman & Jewell to:

**Freeman & Jewell
1422 Peralta Avenue
Berkeley, CA 94702**

We are unable to accept credit cards. Please do not send cash.

Caltrans has recognized these courses as being eligible for reimbursement as an education/professional development expense.

In order to keep administrative costs down, we are unable to provide advanced documentation to governmental agencies in order for them to cut payment checks directly to us. Please apply for reimbursement after the course. We will be happy to provide certificates of completion upon your request. Acknowledgement of payment and receipts are sent to all registered parties.

More Comments by former students

*"I have now successfully passed all 5 sections. I credit you and your courses for that, and appreciate all that you taught us. Very helpful indeed."
Troy Cook, Salt Lake City, UT 08*

*"I passed sections A, B, D, and Site Design section C the first time I took them. I will take E for the first time in June. Thank you so much for all of your help and support throughout this process. I truly believe that I would not have even come close to passing if I had not taken your classes. Thanks again!"
Vicky Wilson, Stockton, CA July and Oct 07*

"Just checked and the scores are posted. I passed all 3 sections!!! This was my first attempt at any of the LARE sections and your class and study materials helped tremendously!!!" Kristen Teddy, Sacramento, CA Jan 07

I can happily tell you that I passed all 3 multiple choice sections. Thanks for the help preparing me for the exam. Your classes were great and I will definitely be back to take your class for the graphic exams. Lucas Piper, Sacramento, CA Jul 11

3. Enrollment

Please enroll me in the following course:

(Check all that apply)

Overview and Intensive Review of Sections A, B and D **Jan 20-22** [\$475]

I would like Option 1 (3 nights +5 extra meals) [\$120]

I would like Option 2 (2 nights +4 extra meals) [\$85]

I would like Option 3 (2 nights room only) [\$50]

I would like Linen (bedding, pillow, and towels) [\$30]

I would like vegetarian meals (including lunch)

I would like vegan meals (including lunch)

4. Payment

Total course fees: \$_____

Additional fee for selected room and board options: \$_____

I enclose a check for \$_____ as full payment for all courses selected, as well as room and board option desired. Make checks payable to: Freeman & Jewell.

5. Customer Information (please print legibly)

Name: Mr. Ms. _____

Address: _____

City: _____ State: _____ Zip: _____

Telephone: _____ (ofc) _____ (cell)(Opt)

E-Mail: _____

Employer: _____

Note: In order to protect your privacy, we prefer to avoid listing home telephone numbers on the class roster. If desired, you may list your employers address. Registration receipts will be mailed to the address you provide on this form. Cell phone numbers are optional.

Please don't send registrations by methods that require a signature for delivery

More Comments by former students

"I happily announce you that I passed all sections-A, B and C of LARE which I took this June. I used your very organized study materials as much as possible until the last minute, and it worked! I really want to recommend your course to everyone who is planning to take the LARE in the future because the materials are all well summarized. I am so glad that I took your course, it is worth it! Your course shows us how to study, and prepare for the exam precisely." Akiko Ishii Spring 03

"I took Sections A, B, and D and passed all three on the first try! Your course definitely helped me prepare for the exams, both mentally and technically." Emily Grant Jan 03

"The results are in from the LARE, and I am happy to report that I passed all three exams. I can hardly believe it! Your prep course was really thorough and covered the exam well." Susan Suddjian, Santa Cruz, CA Jan 07

"Thank you and your classes! I passed all five sections. I knew I was going to pass Section C and E because they seemed to be rather easy - Or they seemed to be easy because I took your classes :-). Again, I'd like to thank you for offering us such good classes and I really appreciate your help." Julie Peng Jan 03

"I took section A, B, D, E and passed them all. Thank you very much for the classes, they really got me motivated and the material was quite good." Li Zhang Fall 02 and Spring 03

"Your course was invaluable and really paid off - I passed all 3! Thank you so much for the concise study material and wonderful course." Lea Allen, Sacramento, CA, Jan 10

"I passed Section D!!!! I am so excited. Your July review class was well worth the journey." Jeanine Thompson, Albany, NY Jul 09

"I passed all 5 sections with the June and August exams at my first time. I'm sure that I would not be able to achieve this without your prep courses and all your help! I've strongly recommended your course to all the people that I know who are going to take the exams." Juan Du, Spring and Summer 04

"I must say that you ran a very well organized and informative seminar. The tools that you presented at the workshop gave me a real sense of confidence when challenging this exam. Thank you!" Steve Clarke, Vancouver, BC Fall 03

"I took your ABD classes & really thought they were excellent. I plan to get my registration in the mail tomorrow for C&E. Please tell me you have spaces left!" Stacy Wons Summer 04